

**SCOPE:**

THIS TECHNICAL DATA BULLETIN EXPLAINS THE TRANSITION FROM THE VERSION 1 TO THE VERSION 2 BOLT AND FIRING PIN FOR THE REVOLUTION (CMR) RIFLE. IT ALSO EXPLAINS THE INTENTIONAL NON-COMPATIBILITY BETWEEN THE 2 SYSTEMS.

**BACKGROUND:**

THE ONGOING DEVELOPMENT OF THE REVOLUTION PLATFORM HAS RESULTED IN THE NEED TO RECONFIGURE THE BOLT AND THE FIRING PIN.

EXPERIMENTATION WITH DIFFERENT CALIBERS, PRIMARILY THOSE WITH HIGHER PRESSURES, RESULTED IN THE REDUCTION OF THE FIRING PIN TIP DIAMETER. THE REDUCED DIAMETER RESULTS IN LESS SIGNS OF PRIMER FLOW AND AIDS IN ELIMINATING PIERCED PRIMERS.

ALSO, THE ADDITION OF THE DIRECT IMPINGEMENT OPERATING SYSTEM OPTION REQUIRED THE BOLT TO BE MODIFIED BY ADDING GROOVES FOR THE GAS RINGS.

PRINCIPALLY, POF-USA BELIEVES IN MAINTAINING A REDUCED AMOUNT OF PART NUMBERS IN ORDER TO ACHIEVE OUR GOALS. SINCE BOTH OF THESE CHANGES BECAME REQUIREMENTS AT AROUND THE SAME TIME, THE DECISION WAS MADE TO IMPLEMENT THEM TOGETHER BY DESIGNING THE V2 BOLT AND V2 FIRING PIN.

**CONSIDERATIONS:**

**THE V2 COMPONENTS ARE NOT COMPATIBLE WITH THE V1 COMPONENTS. THE V1 COMPONENTS ARE NOT COMPATIBLE WITH THE V2 COMPONENTS.**

*THE V2 FIRING PIN WILL NOT FIT INTO A V1 BOLT.*  
IF THE SMALLER TIPPED V2 FIRING PIN WAS USED IN A V1 BOLT, THE RESULT WOULD BE NON IGNITION OR PIERCED PRIMERS ON MOST, IF NOT ALL AMMUNITION ATTEMPTED TO BE FIRED FROM THE FIREARM. WE HAVE ADDED A SHOULDER TO THE REAR OF THE FIRING PIN TO PREVENT THIS.  
THIS IS ILLUSTRATED ON SHEET 2

*THE V1 FIRING PIN WILL NOT FULLY FIT INTO A V2 BOLT.*  
THE V1 FIRING PIN TIP DIAMETER WILL NOT PASS THROUGH THE TIGHTER DIAMETER OF THE V2 BOLT.  
THIS IS ILLUSTRATED ON SHEET 3

**COMPONENT UPGRADES AND REPLACEMENT:**

THE FOLLOWING SERVICE PART SKUS ARE CURRENT AT THE TIME OF THIS DOCUMENT'S RELEASE:  
01494 - V2 BOLT ASSEMBLY  
01492 - V2 FIRING PIN  
01493 - V2 BOLT

THE FOLLOWING SERVICE PART SKUS HAVE BEEN DISCONTINUED AND SHOULD BE REPLACED WITH THE SKUS ABOVE WHEN NEEDED:  
01409 - V1 BOLT ASSEMBLY. (REPLACE WITH V2 BOLT ASSEMBLY)  
01411 - V1 FIRING PIN. (REPLACE WITH 01492 V2 FIRING PIN AND 01493 V2 BOLT)  
01408 - V1 BOLT (REPLACE WITH 01493 V2 BOLT AND 01492 V2 FIRING PIN)

IF YOU HAVE ANY QUESTIONS, CONTACT POF-USA CUSTOMER SERVICE  
PHONE: (623)561-9572  
EMAIL: SALES@POF-USA.COM

REVISION HISTORY				
ZONE	REV.	DESCRIPTION	DATE	APPROVED
	-	INITIAL RELEASE	12/26/2018	B. KLAR

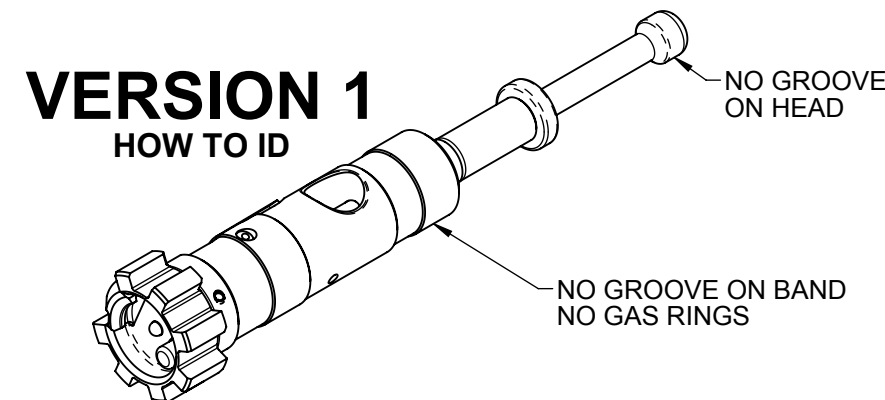
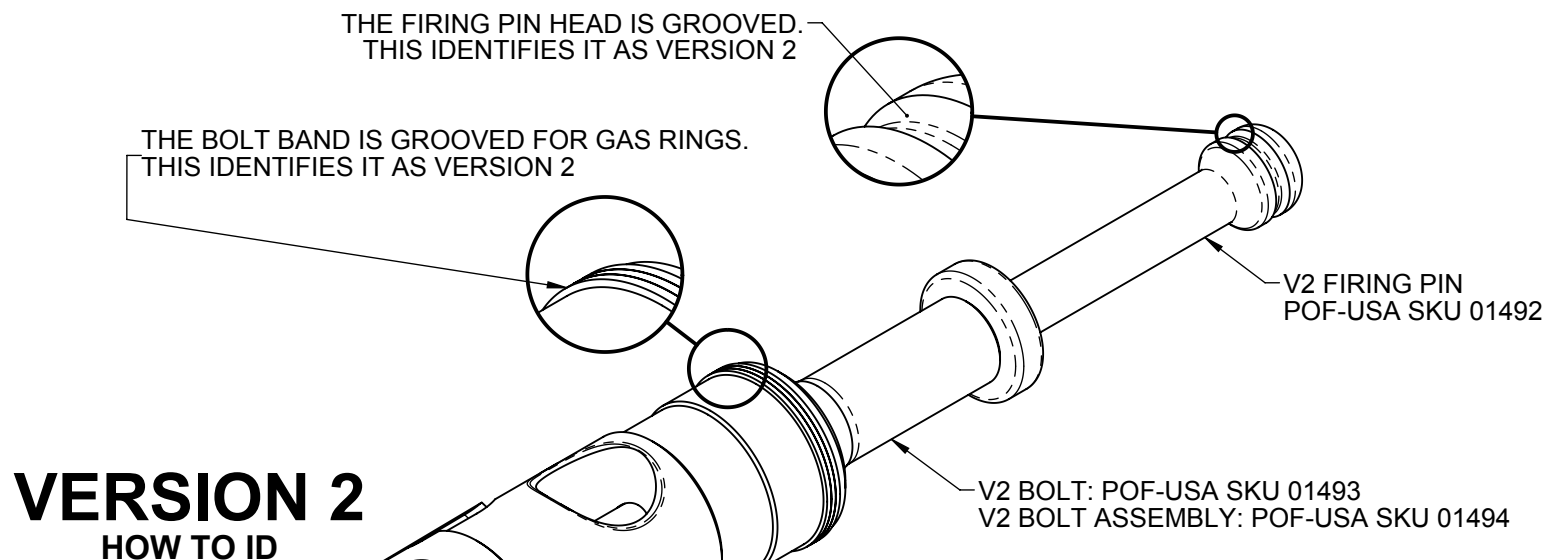

THE INFORMATION CONTAINED IN THIS DOCUMENT IS THE SOLE PROPERTY OF PATRIOT ORDNANCE FACTORY, INC. ANY REPRODUCTION IN WHOLE OR IN PART WITHOUT THE WRITTEN PERMISSION OF PATRIOT ORDNANCE FACTORY IS STRICTLY PROHIBITED.

THIS DOCUMENT IS SUBJECT TO THE ARMS EXPORT CONTROL ACT (22 U.S.C. 7728) AND THE INTERNATIONAL TRAFFIC IN ARMS REGULATIONS (22 C.F.R. PARTS 120-130). A PRIOR AUTHORIZATION OR LICENSE FROM THE U.S. STATE DEPARTMENT DIRECTORATE OF DEFENSE TRADE CONTROLS IS REQUIRED TO EXPORT, RE-EXPORT, RETRANSFER OR SHOW THIS DOCUMENT TO ANY FOREIGN PERSON WHETHER IN THE UNITED STATES OR ABROAD.

THIRD ANGLE PROJECTION

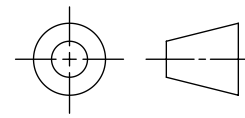

CAD GENERATED DRAWING DO NOT MANUALLY UPDATE	
APPROVALS	DATE
MODELED BY B. KLAR	12/17/2018
DRAWN BY B. KLAR	12/17/2018
ENGINEERING	----
MANUFACTURING	----
QUALITY	----

<b>POF USA</b> Patriot Ordnance Factory			
DRAWING TITLE <b>TECHNICAL BULLETIN REVOLUTION / CMR V2 BOLT ASSY &amp; COMPONENTS</b>			
SIZE <b>B</b>	CAGE CODE <b>4Y6X4</b>	DRAWING NUMBER <b>100756</b>	REV LTR -
SCALE 1:1		WEIGHT -	SHEET 1 OF 3

4

3

2

1

# WHY THE V2 FIRING PIN WONT FIT INTO THE V1 BOLT

SEE SHEET 1 FOR REVISION INFORMATION

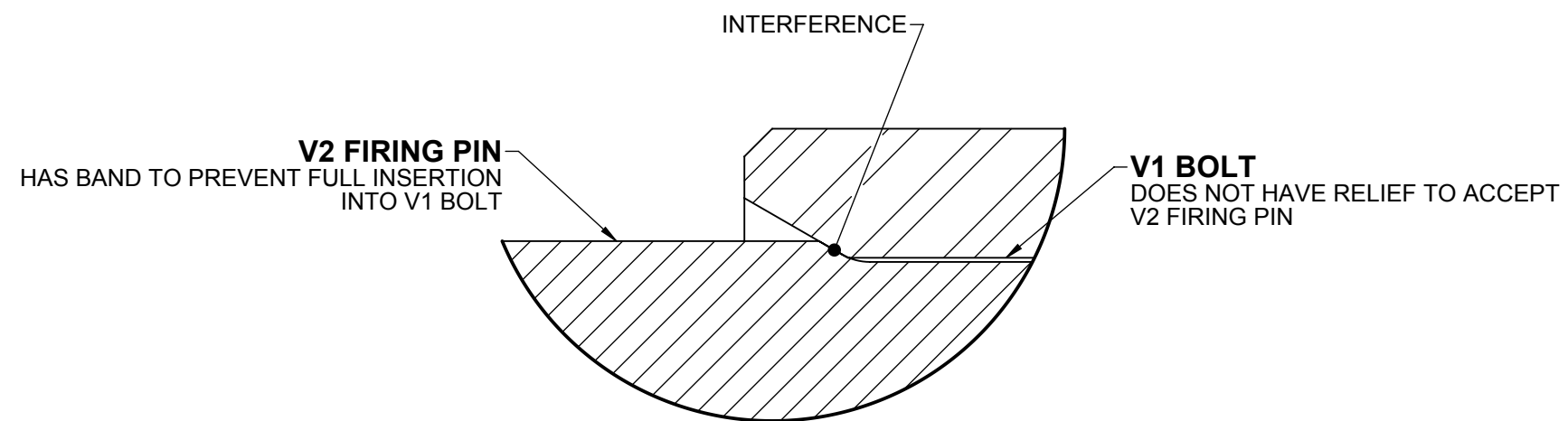

DETAIL F  
SCALE 16X

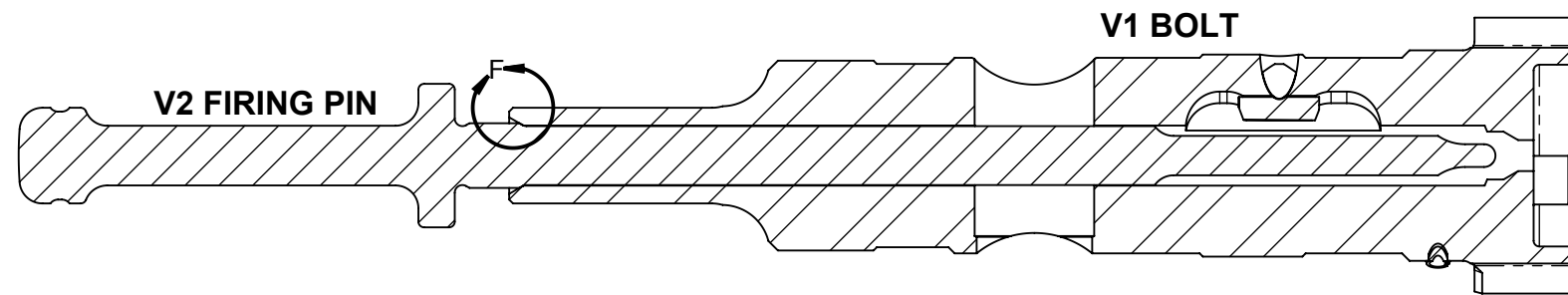

SECTION C-C  
SCALE 2X

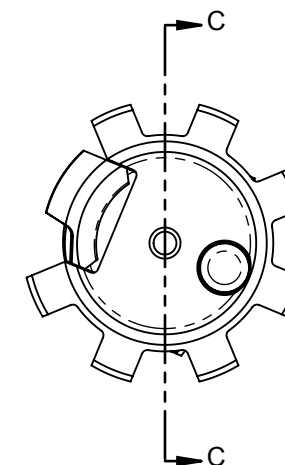

THE INFORMATION CONTAINED IN THIS DOCUMENT IS THE SOLE PROPERTY OF PATRIOT ORDNANCE FACTORY, INC. ANY REPRODUCTION IN WHOLE OR IN PART WITHOUT THE WRITTEN PERMISSION OF PATRIOT ORDNANCE FACTORY IS STRICTLY PROHIBITED.

SIZE	CAGE CODE	DRAWING NUMBER	REV LTR
B	4Y6X4	100756	-
SCALE 1:1		WEIGHT -	SHEET 2 OF 3

4

3

2

1

4

3

2

1

# WHY THE V1 FIRING PIN WONT FIT INTO THE V2 BOLT

SEE SHEET 1 FOR REVISION INFORMATION

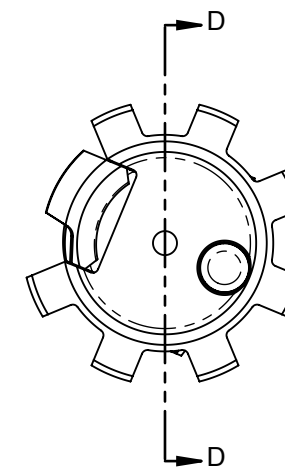
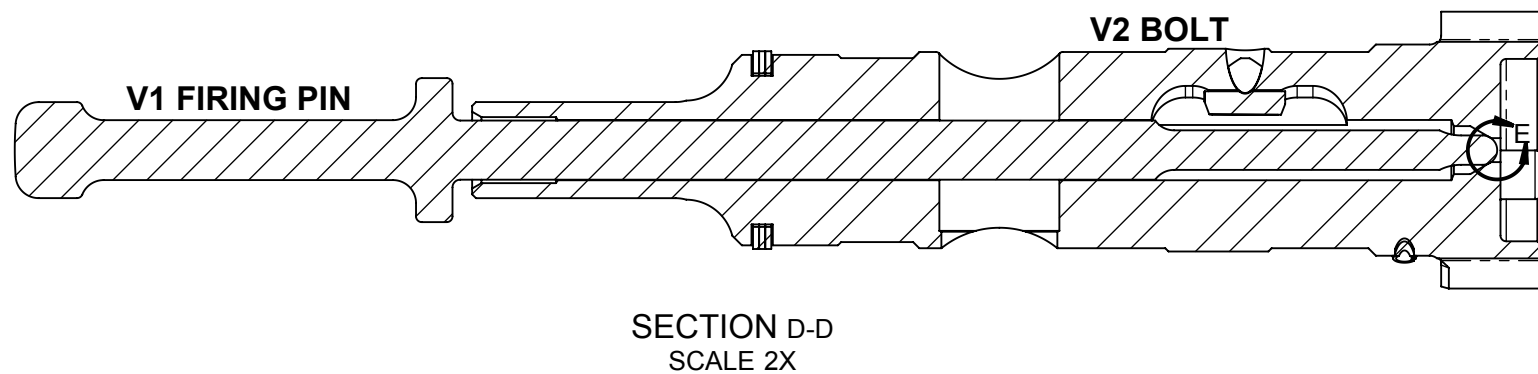
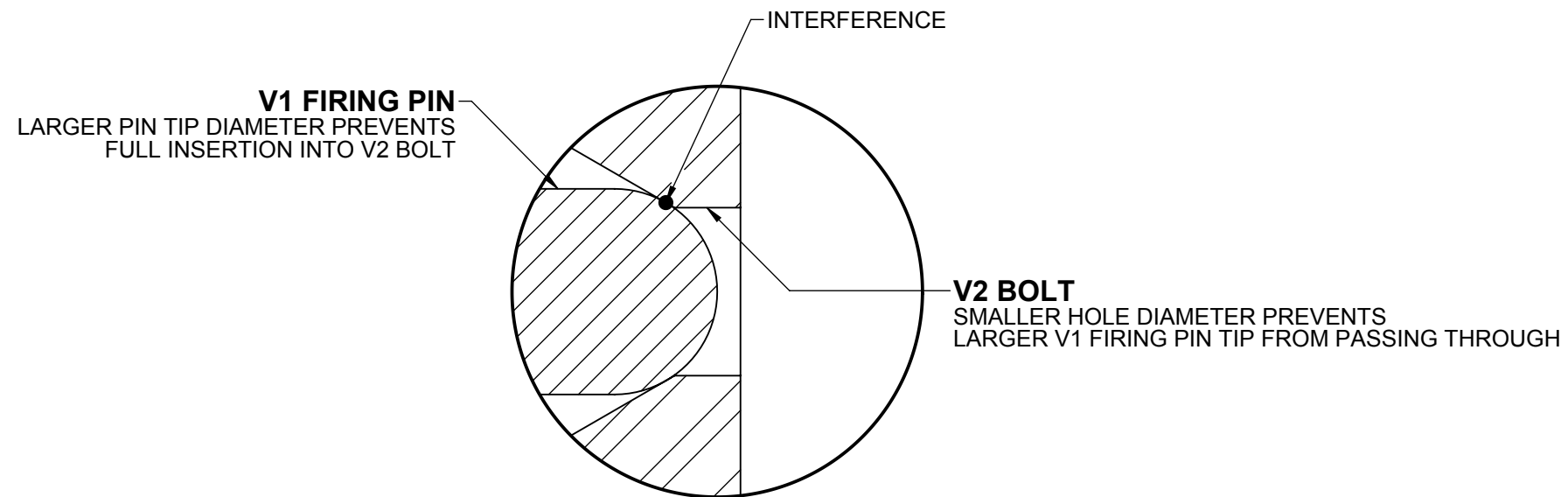

THE INFORMATION CONTAINED IN THIS DOCUMENT IS THE SOLE PROPERTY OF PATRIOT ORDNANCE FACTORY, INC. ANY REPRODUCTION IN WHOLE OR IN PART WITHOUT THE WRITTEN PERMISSION OF PATRIOT ORDNANCE FACTORY IS STRICTLY PROHIBITED.

SIZE	CAGE CODE	DRAWING NUMBER	REV LTR
B	4Y6X4	100756	-
SCALE 1:1		WEIGHT -	SHEET 3 OF 3

4

3

2

1